



The monitored junction box for DC series

Benefits of the system



- Quick and simple mounting
- Fully preassembled and ready for installation
- Verification of correct connection of the DC series
- Overcurrent protection Fuses in + and in -
- Overvoltage protection
- Permanent monitoring of the system:
 - Power generation
 - Current per each string
 - Voltage
 - Fuse and protections status
 - Warnings and alarms



www.suntrack.es



Ctra. Bilbao - Balmaseda Km 9, Mod. 48
48810 Alonsotegi - Spain
Tel.: + 34 944 982 028
Fax: + 34 944 982 036
e-mail: info@suntrack.es



Monitored Junction Box



string Box

The monitored **String-Box** implements advanced features such as monitoring the status of the string currents, evaluating their performances and detecting possible problems or faulty/shaded strings, which may result in reduced yield.

Diagram of the System

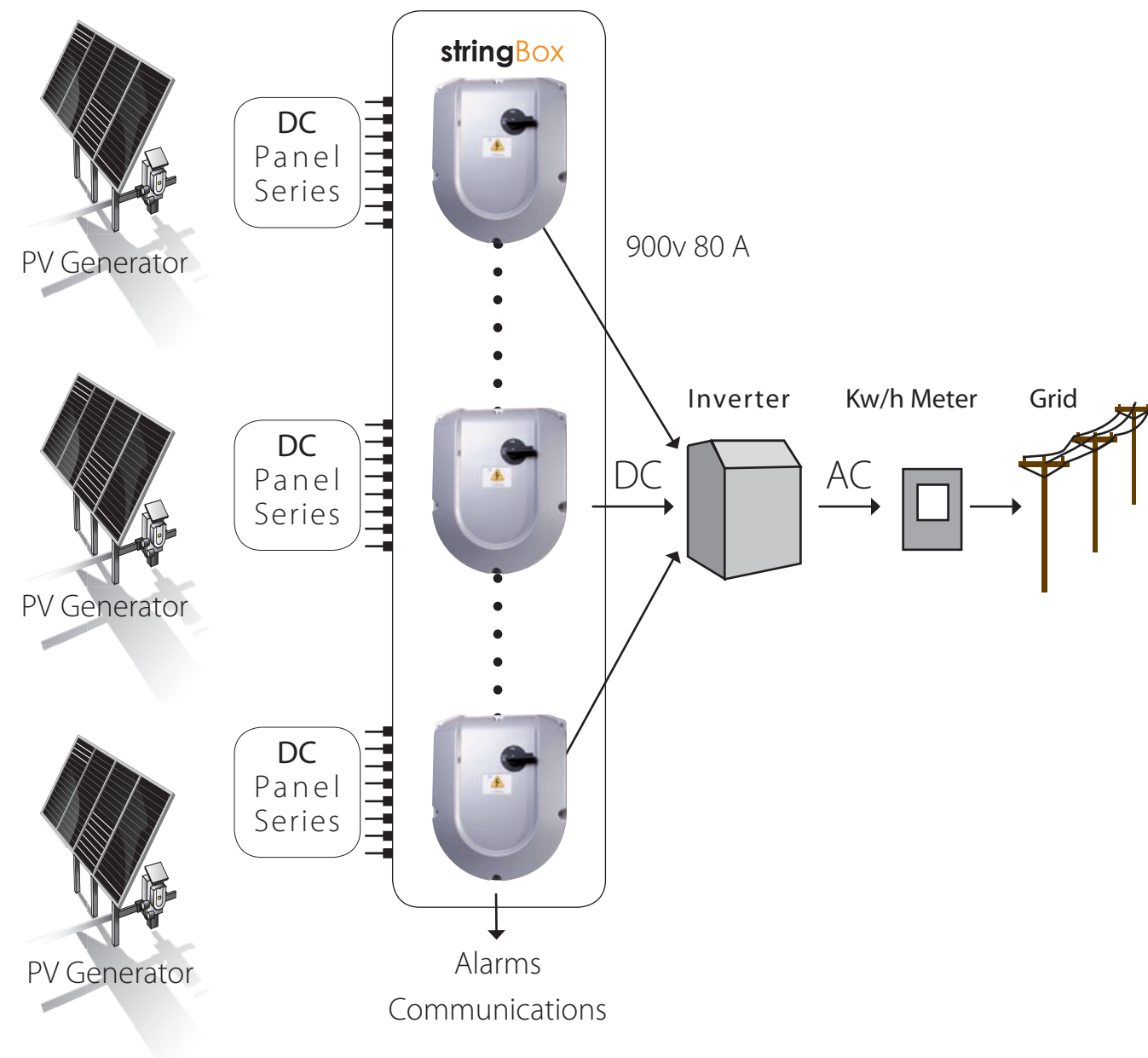

Main Switch 900v 80 Amps

Aluminum IP67 cabinet

System Specifications

- Aluminum cast IP67 cabinet
- 8 string parallel connection (10 Amps)
- Maintenance free string wire plugs
- Active Disconnecter on all poles 1000Vdc
- Overcurrent protection on each string on + and -
- Inverse polarity detection during installation. LED indicator (green-red)
- Easy to substitute overvoltage protections
- Blown fuse detection
- Configuration PC SW application
- RS485 (Modbus) communication



Description of System Elements

